

## RESEARCH PAPER

# Non-thermal Inactivation of *Escherichia coli* in Pineapple juice by Pulsed Light Treatment

P. Preetha<sup>1\*</sup>, N. Varadharaju<sup>2</sup>, Z. John Kennedy<sup>3</sup>, D. Malathi<sup>4</sup> and B. Shridar<sup>5</sup>

<sup>1</sup>Dept. of Food and Agri. Process Engg., <sup>2</sup>Professor and Head, <sup>3,4</sup>Professor, Post-Harvest Technology Centre, <sup>5</sup>Professor and Head, AMRC, AEC & RI, Tamil Nadu Agricultural University, Coimbatore-641 003, India

\*Corresponding author: preethafoodtech@gmail.com

Paper No. 113

Received: 15-9-2015

Accepted: 14-3-2016

---

### Abstract

Pulsed light is an emerging non-thermal processing technology which is mainly used for food decontamination. In this study, pineapple juice was exposed to pulsed light to inactivate the *E.coli* cells using different process parameter such as depth of the juice (5, 10, 15 and 20mm), shelf-height (5, 10 and 15cm) and number of pulses (60,120, 180 and 240 flashes) corresponding to an fluence of 4.8J/cm<sup>2</sup>, 9.6J/cm<sup>2</sup>, 14.4J/cm<sup>2</sup> and 19.2J/cm<sup>2</sup>. Sterilized tender coconut was inoculated with *E.coli* culture of 10<sup>7</sup> cfu/ml. Treatments led to maximum reduction of 6.3 log cfu/ml. *E.coli* reduced with increase in the number of pulses. Inactivations are achieved on the thin layer of juice (5mm) at a nearer distance (5cm) from the lamp with 240 flashes. By varying the process parameter, reduction in *E.coli* had a significant effect (p< 0.05). Quality characteristics such as soluble solids, pH, color, acidity, Vitamin C and Total phenols does not show statistical difference (p<0.05) after testing in different process parameter of Pulsed light treatment. This could be an alternative technology for thermal processing without compromising both quality and safety of the juice.

**Keywords:** Pulsed light, pineapple juice, process parameter, *E.coli* inactivation, quality parameters

---

Pineapple juice is renowned for its sweet and sour taste and it has some health beneficial compounds such as bromelain (a proteolytic enzyme with therapeutic effect) and phenols (Hale *et al.*, 2005). Bromelain exhibits therapeutic and pharmacological effects such as anti-inflammatory, tumour growth modulation and aid in digestion (Hale, 2004). Phenols are known for antioxidant properties.

Frequent consumption of the natural antioxidants prevents cancer and lower cardiovascular diseases. Pineapple juice is well accepted apart from its health benefits it has striking mouthfeel and yellowish colour. It has low polyphenol oxidase activity hence, there will not be any enzymatic browning (Das *et al.*, 1997; Chaisakdanugull *et al.*, 2007; Perera *et al.*, 2010). Since pineapple juice has higher water content (Purseglove, 1972), it is susceptible to quick physico-

chemical and microbiological degradation, therefore has to be processed to prevent spoilage. Processing means conventional heat pasteurization, which may affect the nutritional qualities of the juice.

Non-thermal technologies as alternatives to thermal treatment are being developed to obtain a food product with better final sensory quality, without neglecting microbial safety (FDA/CFSAN report, 2000; Woodling and Moraru, 2005). FDA (2013) has stated that for fruit juices should have a minimum 5 log cycles reduction for human consumption.

Pulsed light (PL) is a technique to decontaminate surfaces by killing microorganisms using short time pulses of an intense broad spectrum, rich in UV-C light. The emitted light flash has a high peak power and consists of wavelengths from 200 to 1100 nm (Dunn *et al.*, 1997) which includes Ultraviolet light,

broad spectrum white light and near infrared light (Green *et al.* 2005). The technique used to produce flashes originates, besides high peak power, a greater relative production of light with shorter bactericidal wavelengths (MacGregor *et al.* 1998).

So this research aims to give a potential system that may be employed in the food processing industry. Since energy consumption in this technology is very less when compared to thermal methods, this technology provides scope for adoption by the industry. The nutrient content of the pineapple juice processed by this method can remain unaltered, there by satisfying the consumer demand for 'wholesome, fresh like foods'. Keeping all these aspects in view an investigation was taken up to develop a process for preservation of pineapple juice by varying the process parameter using pulsed light treatment and the results obtained are discussed here.

## Materials and Methods

### Extraction of the pineapple juice

The crown portion and sides were trimmed-off and the fruit was sliced and the outer skin was peeled off with a curved knife. The peeled slices were cored and then, cut into small pieces, which were passed through a centrifugal extractor (Kenstar food processor, Kitchen appliances, India) where the fruit was crushed and the juice was extracted from the fruit by the centrifugal force. The extracted juice were filtered using a muslin cloth.

### Inoculation of *E.coli* culture

*Escherichia coli* culture (obtained from MTCC) was grown on nutrient agar (NA) broth at 37°C for 24 h reaching a stationery phase count of 10<sup>9</sup> cfu/ml. Cells collected by centrifuging (Rotor no. A4-44 producing a relative centrifugal force of 10,375) at room temperature and rinsing with 0.1% peptone prior to inoculation in to juices at an initial level of count approximately at 10<sup>6</sup> to 10<sup>7</sup> cfu/ml. A working culture was prepared by aseptically transferring a colony from NA plates in to fresh NA broth that was again incubated at 37°C for 24 h. For inoculation to pineapple juice at final count

of ≤10<sup>7</sup> cfu/ml culture was added directly (Ngadi *et al.* 2003).

### Sterilization of pineapple juice

The fresh pineapple juice was autoclaved at 121°C at 1.5 bar for 15 min. The volume of water obtained ranges from average 360 to 500 ml. The sterilized juice sample was inoculated with *E.coli* cells of 10<sup>7</sup> cfu/ml. Pulsed light treatment were carried out using an laboratory system (Fig. 1), equipped with standard clear 75mm long transparent quartz Xenon Lamp (Make: Hereus Noblelight, U.K) which had a bore diameter of 3 mm. Pulse width of 40 micro second. Pineapple juice was poured in a petri dish (100mm diameter) and placed inside the treatment chamber. The samples ware exposed to receive 0.08 J/cm<sup>2</sup> per pulse. The treatment of 60, 120,180, 240 flashes were given thus resulting in an overall fluence ranging from 4.8 J/cm<sup>2</sup> to 19.2J/cm<sup>2</sup>. The treated samples, covered carefully were transferred to aseptic laminar air flow chamber where they were bot led in glass bot les.

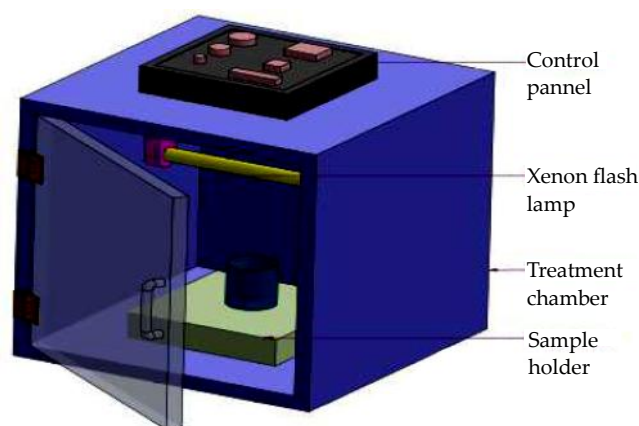

**Fig. 1:** Experimental Apparatus - Laboratory model of Pulsed light treatment apparatus

### Quality characteristics

The TSS (total soluble solids) was determined using a digital hand held refractometer (Atago Co., Tokyo, Japan) and the total soluble solid content was expressed as °Brix at 25°C (AOAC, 1980). The pH of juice was measured using digital pH meter (Cyber scan, India) at 25°C. The colour of juice was measured using a Hunter lab colour flux meter (Hunter Associate Laboratory, Inc., Reston) which provides

colour values in the terms of L, a, and b, where L indicates whiteness to darkness, a (+) redness, a (-) greenness, b(+) yellowness and b (-) blueness.

$$\Delta E = (\Delta a^2 + \Delta b^2 + \Delta L^2)^{1/2} \quad (1)$$

$\Delta L = L_{\text{Sample}} - L_{\text{Standard}}$  +  $\Delta L$  - sample is lighter than standard  
 -  $\Delta L$  - sample is darker than standard  
 $\Delta a = a_{\text{Sample}} - a_{\text{Standard}}$  +  $\Delta a$  - sample is redder than standard  
 -  $\Delta a$  - sample is greener than standard  
 $\Delta b = b_{\text{Sample}} - b_{\text{Standard}}$  +  $\Delta b$  - sample is yellower than standard  
 -  $\Delta b$  - sample is bluer than standard

Vitamin C were determined by visual titration using 2,6-dichlorophenol-indophenol (Ranganna, 1995).

Ascorbic acid (mg/100g) =

$$\frac{(0.5/V_1 \times V_2/5 \text{ ml} \times 50\text{ml})}{\text{Weight of the sample}} \times 100 \quad \dots(2)$$

Titrateable Acidity was determined by titrating a known volume of juice with 0.01N NaOH to an end point of pink colour using phenolphthalein as an indicator. The NaOH required to neutralize the juice and Titrateable acidity was calculated and expressed as % citric acid:

Titrateable Acidity =

$$\frac{(N \times V \times \text{Equivalent weight of acid} \times 100)}{\text{Weight of the sample taken}} \times 100 \quad \dots(3)$$

Total phenol content were determined by with Folin-Ciocalteu reagent (Sadasivam and Manickam, 1992) using gallic acid as a Standard.

### Statistical Analysis

All the analyses were carried out in triplicate. The results are expressed as mean values and standard deviation (SD). The optimisation of number of flashes to the sample 120, 180 and 240 flashes, shelf-height from the lamp- 5, 10 and 15cm from the lamp, juice depth of the juice - 5, 10, 15 and 20mm for the Pulsed light treatment process was done using the Factorial Completely Randomized Design (FCRD) and were analysed using analysis of variance (ANOVA)

followed by Least Significant Difference (LSD) Test with  $\alpha=0.05$ . This treatment was carried out using AGRESS sof ware version 7.01.

## Results and Discussion

### Inactivation of *E.coli*

#### Effect of fluence on the inactivation of *E.coli*

Higher intensity had a greater reduction in the *E.coli* population is shown in the Fig. 2. Log reduction achieved after PL treatment with a fluence of 4.8 J/cm<sup>2</sup> ranged from 3.7 log CFU/ml where delivered maximum energy of 19.2 J/cm<sup>2</sup> to 6.3 log reduction. The energy for one pulse was 0.08 J/cm<sup>2</sup> whereas for 60, 120, 180 and 240 pulses delivered a 4.8 J/cm<sup>2</sup>, 9.6 J/cm<sup>2</sup>, 14.4 J/cm<sup>2</sup> and 19.2 J/cm<sup>2</sup>.

A maximum log reduction of 6.3 can be achieved using the pulsed light technology for pineapple juice. FDA has recommended that at least a 5 log reduction of more resistant micro-organism under specific operating conditions.(US FDA, 2001, 2004). By differing the number of pulses, reduction in *E.Coli* had a significant effect ( $p < 0.05$ ). The sensitivity of the micro organism to PUV depend's on the presence of proteins that absorb the UV light (Koutchma, 2008). Huffman *et al.* (2000) treated water at 0.25 J/cm<sup>2</sup> gave a reduction of  $>7.4 \log_{10} \text{cfu/ml}$  for *klebsiella terrigena* after two pulse. These results showed that transparency of the media allowed successful microbial inactivation using this technology. Sauer and Moraru (2009) studied the effect of PL treatment in liquid foods with different in the level of clarity such as but erfield's phosphate buffer, tryptic soy broth, apple juice and apple cider. They found that susceptibility decreased based on clarity.

#### Effect of juice depth on the inactivation of *E.coli*

Figure 3 presents the effect of depth of the pineapple juice on the inactivation of *E.coli*, where the sample was treated at a distance of 15cm. At a lower depth of 5mm juice treated under a maximum dose of 19.2J/cm<sup>2</sup> which were found to obtain a maximum log reduction of 5.8. By decreasing the depth of the juice at different fluence of 4.8 J/cm<sup>2</sup>, 9.6J/cm<sup>2</sup>, 14.4J/cm<sup>2</sup>

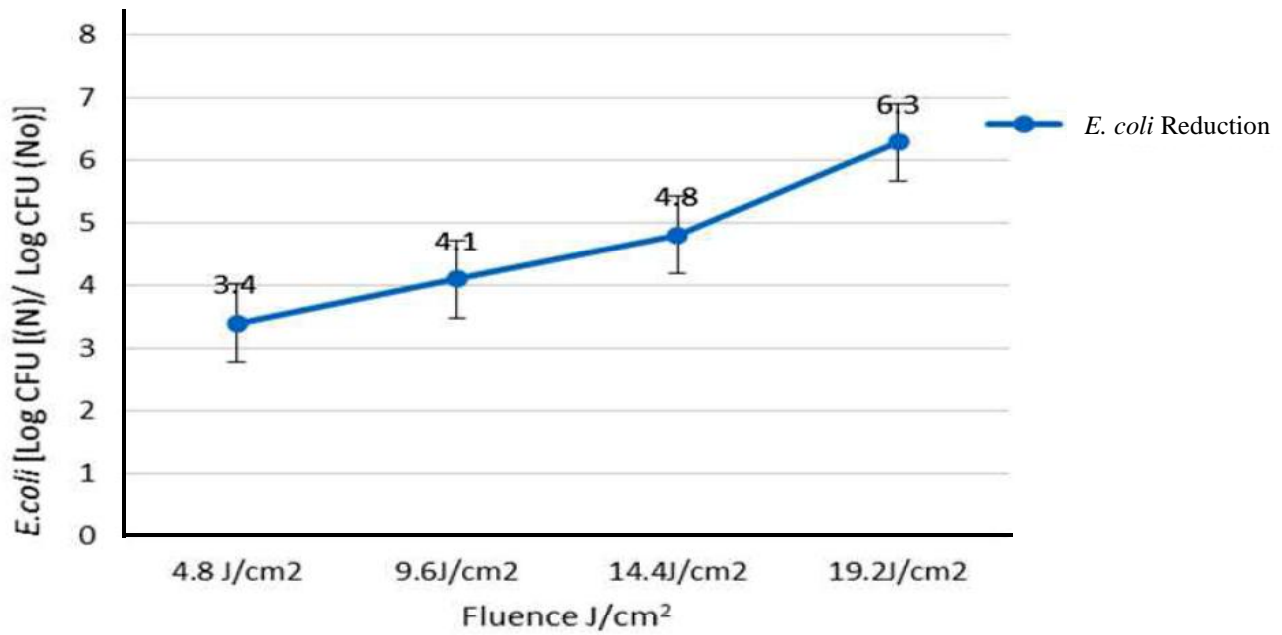

Fig. 2: Effect of the fluence in the on the inactivation of *E. coli* in pineapple juice at a distance of 15 cm from the lamp

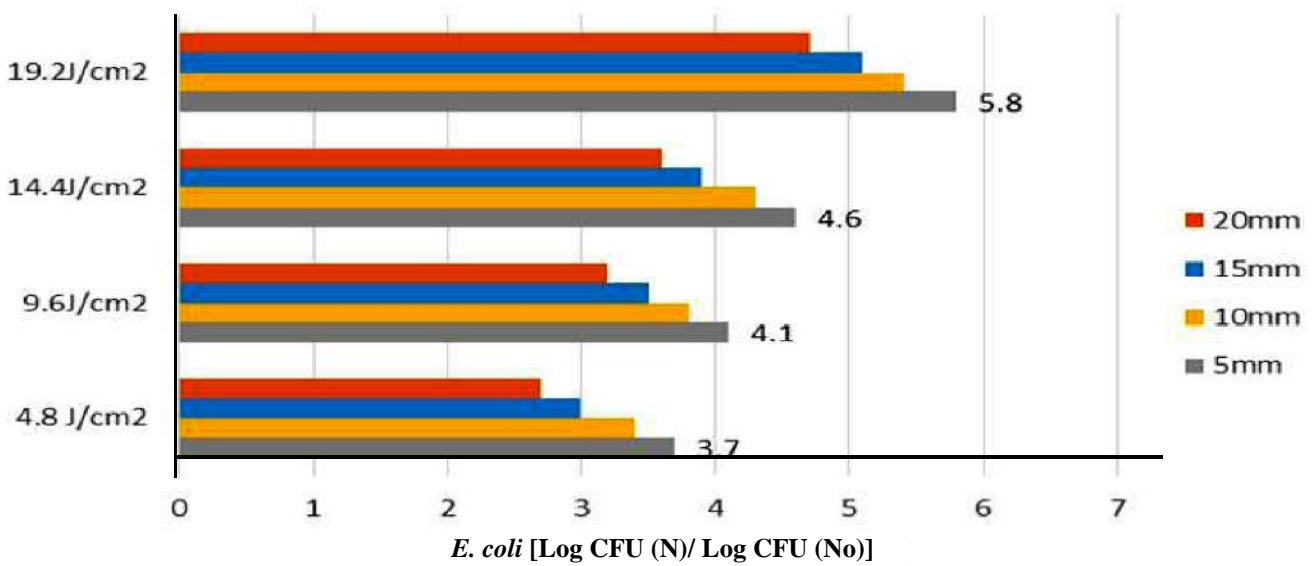
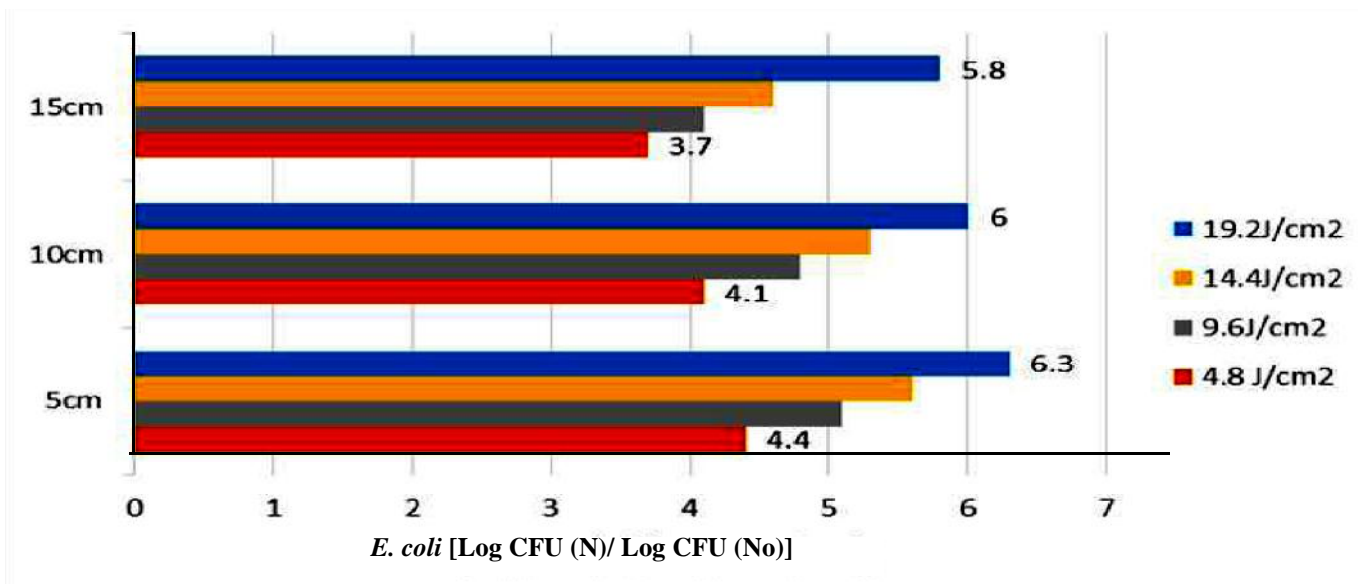

Fig. 3: Effect of the depth of the pineapple juice on the inactivation of *E. coli* at a distance of 15cm from the lamp

(19.2 J/cm<sup>2</sup>, 14.4J/cm<sup>2</sup>, 9.6J/cm<sup>2</sup> and 4.8J/cm<sup>2</sup> – Fluence applied. 20, 15, 10 and 5mm indicates the depth of the pineapple juice exposed to the pulsed light treatment).



**Fig. 4:** Effect of distance from the lamp on the inactivation of *E.coli* in the pineapple juice

(5cm, 10cm and 15cm indicates the distance from the lamp (Shelf-height) and 19.2 J/cm<sup>2</sup>, 14.4 J/cm<sup>2</sup>, 9.6 J/cm<sup>2</sup> and 4.8 J/cm<sup>2</sup> are the fluence obtained in the pulsed light).

cm<sup>2</sup>, 19.2J/cm<sup>2</sup>, inactivation efficiency increased to maximum reduction of 3.7, 4.1, 4.6 and 5.8 log reduction. In juice products 90 percent of light absorption occurs at minimum depth (Keyser *et al.* 2008). From the Figure 3, it is clear that by increasing the depth of the juice reduces the microbial reduction. 20mm depths of the juice had only 4.7 log reduction at a maximum fluence of 19.2J/cm<sup>2</sup>. The statistical analysis demonstrated significant differences between the inactivation of *E.coli* using different depth of the juice ( $p < 0.05$ ). This may be due to the absorption capacity of the juice and was found to be well more critical factor influencing the PL treatment (Maf ei *et al.* 2014). Microbial destruction obtained by this study is consistent with those documented by other researchers using different media. Hillegas and Demirci (2003) reported that 2mm layer depth of honey had a 73.9 per cent reduction in the count of *Clostridium sporogenes* spores whereas for 8mm it had only 14.2 per cent.

#### *Influence of the distance from the lamp on the inactivation of E.coli*

Inactivation of *E.coli* in the pineapple juice processed

by Pulsed light (PL) at different shelf-height is shown in the Figure 4. At a fluence of maximum 19.2 J/cm<sup>2</sup> dose, there exhibit a 6.3 log reduction at a nearer distance of 5cm from the lamp. By increasing the distance of the lamp, the absorption of light to the sample gets reduced, so there were only 6, 5.8 log reduction at a distance of 10cm and 15cm. The microbial inactivation was higher at a distance of 5cm, this may be due to the more absorption of the light rays by the sample. Similar results have been obtained by the Hillegas and Demirci (2003) for honey treating at a distance of 20cm. Microbial inactivation had a statistically significant ( $p < 0.05$ ) effect on the difference in the distance from the lamp

#### *Physico-chemical properties of PL treated Pineapple juice*

The soluble solids, pH, titratable acidity, vitamin C and total phenols of the pineapple juice are presented in the Table 1. The data did not show any statistical difference ( $p < 0.05$ ), after testing in different process parameters of Pulsed light treatment which is in agreement with Choi *et al.* (2002), Francis and

**Table 1: Effect of the pulsed light on pH, soluble solids, colour, acidity, Vitamin C and Total phenols of the pineapple juice**

Shelf height (cm)	Flashes (Number)	Depth of the juice (mm)	pH	TSS (°B)	Colour	Titration Acidity (% citric acid)	Vitamin C (mg/100ml)	Total Phenols (g/100ml)
5	120	5	4.37	6.5	0.43	0.0067	20.8	0.0094
		10	4.38	6.5	0.51	0.0067	21.0	0.0094
		15	4.38	6.6	0.56	0.0067	21.2	0.0095
		20	4.39	6.6	0.6	0.0066	21.4	0.0095
	180	5	4.36	6.4	0.46	0.0067	20.0	0.0094
		10	4.36	6.4	0.52	0.0066	20.2	0.0094
		15	4.37	6.4	0.59	0.0067	20.4	0.0094
		20	4.37	6.5	0.63	0.0067	20.7	0.0094
	240	5	4.35	6.3	0.47	0.0066	19.2	0.0093
		10	4.35	6.3	0.56	0.0067	19.4	0.0093
		15	4.36	6.4	0.64	0.0067	19.6	0.0093
		20	4.37	6.4	0.68	0.0067	19.8	0.0093
10	120	5	4.42	6.7	0.14	0.0068	23.4	0.0096
		10	4.42	6.7	0.24	0.0067	23.6	0.0096
		15	4.43	6.7	0.37	0.0067	23.7	0.0097
		20	4.43	6.8	0.41	0.0068	23.9	0.0097
	180	5	4.41	6.6	0.16	0.0067	22.6	0.0095
		10	4.41	6.6	0.21	0.0068	22.8	0.0095
		15	4.41	6.7	0.33	0.0068	23.0	0.0096
		20	4.42	6.7	0.43	0.0067	23.2	0.0096
	240	5	4.38	6.6	0.36	0.0068	21.6	0.0095
		10	4.39	6.6	0.44	0.0067	21.8	0.0095
		15	4.4	6.6	0.48	0.0067	22.1	0.0095
		20	4.4	6.7	0.52	0.0068	22.4	0.0095
15	120	5	4.44	6.9	0.4	0.0068	25.2	0.0098
		10	4.44	6.9	0.46	0.0068	25.2	0.0098
		15	4.45	6.9	0.54	0.0067	25.3	0.0098
		20	4.45	7	0.62	0.0068	25.3	0.0098
	180	5	4.42	6.8	0.52	0.0067	24.8	0.0097
		10	4.42	6.8	0.56	0.0068	24.9	0.0097
		15	4.43	6.9	0.66	0.0067	25	0.0098
		20	4.44	6.9	0.75	0.0068	25	0.0098
	240	5	4.42	6.8	0.46	0.0067	24.0	0.0097
		10	4.43	6.8	0.52	0.0066	24.2	0.0097
		15	4.44	6.8	0.56	0.0067	24.4	0.0097
		20	4.45	6.8	0.58	0.0068	24.5	0.0097

	pH			TSS			Colour		
	SED	CD(0.05)	CD(0.01)	SED	CD(0.05)	CD(0.01)	SED	CD(0.05)	CD(0.01)
<b>S</b>	0.00223	0.00445	0.00591	0.01843	0.03673	0.04875	0.00209	0.00417	0.00553
<b>F</b>	0.0223	0.00445	0.00591	0.01843	0.03673	0.04875	0.00209	0.00417	0.00553
<b>D</b>	0.00258	0.00514	0.00682	0.02128	0.04241	0.05629	0.00241	0.00481	0.00639
<b>SF</b>	0.00387	0.00771	0.01024	0.03191	0.06362	0.08444	0.00362	0.00722	0.00958
<b>FD</b>	0.00447	0.00891	0.01182	0.03685	0.07346	0.0975	0.00418	0.00834	0.04107
<b>SD</b>	0.00447	0.00891	0.01182	0.03685	0.07346	0.0975	0.00418	0.00834	0.04107
<b>SFD</b>	0.00774	0.01543	0.02047	0.06383	0.12724	0.16888	0.00724	0.01444	0.01917

	Acidity			Vitamin C			Phenols		
	SED	CD(0.05)	CD(0.01)	SED	CD(0.05)	CD(0.01)	SED	CD(0.05)	CD(0.01)
<b>S</b>	0.00001	0.00003	0.00004	0.02164	0.04313	0.05725	0.00002	0.00003	0.00004
<b>F</b>	0.00001	0.00003	0.00004	0.02164	0.04313	0.05725	0.00002	0.00003	0.00004
<b>D</b>	0.00002	0.00003	0.00004	0.02498	0.0498	0.0661	0.00002	0.00004	0.00005
<b>SF</b>	0.00002	0.00005	0.00006	0.03747	0.0747	0.09915	0.00002	0.00005	0.00006
<b>FD</b>	0.00003	0.00005	0.00007	0.04327	0.08626	0.11449	0.00003	0.00005	0.00006
<b>SD</b>	0.00003	0.00005	0.00007	0.04327	0.08626	0.11448	0.00003	0.00005	0.00006
<b>SFD</b>	0.00005	0.00009	0.00012	0.07495	0.14941	0.1983	0.00005	0.00011	0.00012

Clydesdale (1975) for orange juice. Pineapple juice treated with maximum pulses of 240 had a slight change in quality parameters but statistically it did not have any significant effect. Similar trend of results were obtained in terms of TSS, pH, color and viscosity by Kashara *et al.* (2004) on clarified apple juice, which was exposed to different energy dose. Color measurements were also performed in this study. The PL treatment did not cause statistically different ( $p < 0.05$ ) browning effect in pulsed light but slightly noticeable change in  $\Delta E$ . This was confirmed based on the instrumental measurement of lightness. Palgan *et al.* (2011) also reported for apple juice that it did not cause any browning after pulsed light treatment. Samples treated with a maximum energy (240 flashes) at minimum distance of 5 cm from the lamp with a depth of 5mm of pineapple juice did not exhibit a color change of greater than 0.5. These results are comparable to these reported by Mafeti *et al.* (2014) who studied the apple juice.

Similar to our results, Noci *et al.* (2008) also observed, after PL treatment in apple juice did not have any noticeable change in pH and soluble solids. The

different energy doses from 1850 mJ/cm<sup>2</sup> to 3354mJ/cm<sup>2</sup> applied to clarified apple juice did not cause significant difference in terms of soluble solids and colour (Kasahara *et al.*, 2004). The instrumental measurement of color for apple juice treated with pulsed light had showed a slightly noticeable change by applying a fluence of 28J/cm<sup>2</sup> (Palagan *et al.* 2011). Performed with different equipment and food samples need case by case analysis.

Pineapple juice had acidity of about of 0.0068 g of citric acid per 100 ml. The pulsed light treatment statistically did not however, show any significant effect ( $P \leq 0.05$ ) on the acidity. The basic purpose of cold sterilization is to minimize the effect of heat treatment. Carnerio *et al.* (2002) also have reported that cold sterilization did not affect the acidity of the pineapple juice.

Vitamin C is a light sensitive vitamin which is lost due to heat treatment, exposure to light, oxygen (Kabasakalis *et al.*, 2000). The vitamin C content of the pineapple juice was 25.3 after the treatment at a distance of 15cm, 20mm depth of juice and at

a lower dose of 120 flashes. By increasing the dose level, however the loss of vitamin C was observed statistically significant ( $P \leq 0.05$ ). At a higher dose of 240 flashes, minimum distance of 5cm from the lamp, minimum depth of 5mm juice had a loss from 25.3 to 19.2 mg/100ml. Tikekar *et al.* (2011) also reported that loss of vitamin C was higher at higher dose in apple juice. Falguera *et al.* (2011) had a similar trend of decrease in Vitamin C by treating pineapple juice with UV treatment.

The total phenol content of the pineapple juice (0.0098 g/100ml) did not vary during the treatment at different process parameter. Falguera *et al.* (2011) also found no variations in phenol content in UV treatment up to 100 min.

## Conclusion

The process parameters also plays a major role in controlling the population of *E.coli* in pineapple juice. The minimum depth, nearer distance and higher number of pulse can achieve more inactivation. Pulsed light (PL) technology does not affect the quality parameters of the pineapple juice when it is treated with different process parameter. Hence, these studies are useful in preserving the pineapple juice using pulsed light. This could serve as an alternative technology for thermal processing without compromising with the quality and safety of the juice.

## References

- Carneiro, L., Dos Santos Sa, I., Dos Santos Gomes, F., Mat a, V. M. and Cabral, L.M.C. 2002. Cold sterilization and clarification of pineapple juice by tangential microfiltration. *Desalination.*, **148**: 93–98.
- Chaisakdanugull, C., Theerakulkait, C. and Wrolstad, R.E. 2007. Pineapple juice and its fractions in enzymatic browning inhibition of banana [Musa (AAA group) Gros Michel]. *Journal of Agricultural and Food Chemistry.*, **55**: 4252 – 4257.
- Choi, M.H., Kim, G.H. and Lee, H.S. 2002. Effects of ascorbic acid retention on juice color and pigment stability in blood orange (*Citrus sinensis*) juice during refrigerated storage. *Food Research International.*, **35**(8): 753-759.
- Das, J.R., Bhat, S.G. and Gowda, L.R. 1997. Purification and characterization of a polyphenol oxidase from the Kew cultivar of Indian pineapple fruit. *Journal of Agricultural and Food Chemistry.*, **45**: 2031-2035.
- Dunn, J., Bushnell, A., Ot, T. and Clark, W. 1997. Pulsed white light food processing. *Cereal Foods World.*, **42**: 510–515.
- Falguera, V., Pagán, J. and Ibarz, A. 2011. Effect of UV irradiation on enzymatic activities and Physico-chemical properties of apple juices from different varieties. *LWT - Food Science and Technology.*, **44**: 115-119.
- FDA/CFSAN. 2000. Kinetics of microbial inactivation for alternative food processing technologies: Pulsed light technology. Center for Food Safety and Nutrition. Accessed on October 2010 ht p://www.cfsan.fda.gov.
- FDA U.S. Food and Drug Administration. 2013a. CFR – Code of Federal Regulations, Title 21. Available from ht p://www.accessdata.fda.gov/scripts/cdrh/cfdocs/cfcfr/CFRSearch.cfm?CFRPart=120& show FR=1. Accessed 2014 March 4.
- Francis, F.J. and Clydesdale, F.M. 1975. Food colorimetry: Theory and applications. Westport: AVI Publishing Company.
- Green, S., Basaran, N. and Swanson, B. 2005. Food preservation techniques. In Zenthen, P. and Bogh Sorenson, L. (Eds). Washington, United States of America: Woodhead Publishing House, p. 365, CRC press.
- Hale, L.P. 2004. Proteolytic activity and immunogenicity of oral bromelain within the Gastro intestinal tract of mice. *International Immunopharmacology.*, **4**(2): 255- 264.
- Hale, L.P., Greer, P.K., Trinh, C.T. and James, C.L. 2005. Proteinase activity and stability of natural bromelain preparations. *International Immunopharmacology.*, **5**(4): 783-793.
- Hillegas, S.L. and Demirci, A. 2003. Inactivation of Clostridium sporogenes in clover honey by pulsed UV-light treatment. *Agricultural Engineering International: the CIGR Journal of AE Scientific Research and Development*, **7**: 03-009.
- Huffman, D.E., Slif o, T.R., Salisbury, K. and Rose, J.B. 2000. Inactivation of bacteria, virus and Cryptosporidium by a point-of-use device using pulsed broad spectrum white light. *Water Research.*, **34**: 2491-2498.
- Kabasakalis, V., Siopidou, D., Moshatou, E. 2000. Ascorbic acid content of commercial fruit juices and its rate of loss upon storage. *Food Chem.* **70**: 325–328.
- Kasahara, I., Kaiser, S., Aguilar, F. and Marillanca, M. 2004. Pasteurisation of apple juice by pulsed ultraviolet light: processing conditions and effect in the product characteristics. In Proceedings of the International Conference Engineering and Food, Montpellier, France.
- Keyser, M., Muller, I.A., Cilliers, F.P., Nel, W. and Gouws, P.A. 2008. Ultraviolet radiation as a non-thermal treatment for the inactivation of microorganisms in fruit juice. *Innovative Food Science & Emerging Technologies*, **9**: 348-354.



- Koutchma, T. 2008. UV light for processing foods. *Ozone Science & Engineering.*, **30**: 93-98.
- MacGregor, S.J., Rowan, N.J., McIlvaney, L., Anderson, J.G., Fouracre, R.A. and Farish, O. 1997. Light inactivation of food-related pathogenic bacteria using a pulsed power source. *Applied Microbiology.* **27**(2): 67-70.
- Mafeti, N.A., Ramos, A.Y.V., Nicolau, A.I., Martin-Belloso, O. and Soliva-Fortuny, R. 2014. Influence of process parameters on the pulsed light inactivation of Penicillin Expansum in apple juice. *Food Control.*, **41**: 27-31.
- Noci, F., Riener, J., Walkling-Ribeiro, M., Cronin, D.A., Morgan, D.J. and Lyng, J.G. 2008. Ultraviolet irradiation and pulsed electric fields (PEF) in a hurdle strategy for the preservation of fresh apple Juice. *Journal of Food Engineering.*, **85**(1): 141-146.
- Palagan, I., Caminiti, I.M., Muñoz, A., Noci, F., Whyte, P., Morgan, D.J., Cronin, D.A. and Lyng, J.G. (2011). Effectiveness of High Intensity Light Pulses (HILP) treatments for the control of *Escherichia coli* and *Listeria innocua* in apple juice, orange juice and milk. *Food microbiology.* **28**: 14-20.
- Perera, N., Gamage, T.V., Wakeling, L., Gamlath, G.G.S. and Versteeg, C. 2010. Colour and texture of apples high pressure processed in pineapple juice. *Innovative Food Science and Emerging Technologies.* **11**: 39 – 46.
- Purseglove, J.W., 1972. Tropical Crops; Monocotyledons, Longman: London, 344.
- Ranganna, S. 1995. Hand book of analysis and quality control for fruits and vegetable products (2<sup>nd</sup> Edn.). Tata McGraw-Hill Publishing Company Limited. New Delhi-2.1995.
- Sadasivam, S. and Manickam, A. 1992. Biochemical methods for agricultural sciences. New Age international Pub. (Pvt.) Ltd., Chennai, India, pp. 246.
- Sauer, A. and Moraru, C.I. 2009. Inactivation of *Escherichia coli* ATCC 25922 and *Escherichia coli* O157: H7 in apple juice and apple cider, using pulsed light treatment. *Journal of Food Protection.* **72**: 37–944.
- Tikekar, R.V., Anantheswaran, R.C. and LaBorde, L.F. 2011. Ascorbic Acid Degradation in a Model Apple Juice System and in Apple Juice during Ultraviolet Processing and Storage. *J Food Sci.*, **76**: 62-71.
- US FDA., 2001. Hazard Analysis and Critical Control Point (HACCP): Procedures for the Safe and Sanitary Processing and Importing of Juice: Final rule. Office of the Federal Register, National Archives and Records Administration.
- US FDA., 2004. Guidance for Industry, Juice HACCP Hazards and Controls Guidance. Office of the Federal Register, National Archives and Records Administration.
- Woodling, S.E. and Moraru, C.I. 2005. Influence of surface topography on the effectiveness of pulsed light treatment for the inactivation of *Listeria innocua* on stainless steel surfaces. *Journal of Food Science.*, **70**(7): M345-M351.

